



# TOBERAS Y MULTITOBERAS

---

## SERIE T

Las toberas están indicadas para su uso en grandes superficies, aeropuertos, centros comerciales y pabellones. Gracias a su impulsión de largo alcance multidireccional, su capacidad para mover altos caudales y su estética; hacen de las toberas un elemento decorativo a la par que funcional.

# TOBERAS Y MULTITOBERAS

## SERIE T

TJB	Tobera de largo alcance
TJNT	Tobera de largo alcance termostática
TO	Tobera de largo alcance orientable
TF	Tobera de largo alcance fija



TJB



TJNT



TO



TF

# SERIE T

## TJB



### TOBERA DE LARGO ALCANCE

Modelo **TJB**. Tobera de largo alcance para impulsión de aire, orientable manualmente en múltiples direcciones y con un ángulo de giro de  $\pm 30^\circ$ .

Fabricada en aluminio.  
Acabado estándar en lacado blanco similar a RAL 9016.

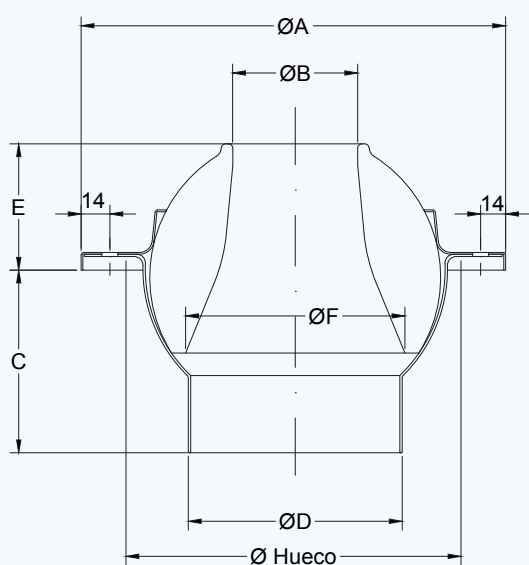
**TJB****TJB**

Vista lateral



	Ø D	Ø A	Ø B	C	E	Ø F	Ø HUECO
<b>TJB 1</b>	120	232	70	105	75	123	185
<b>TJB 2</b>	175	298	100	115	100	168	250
<b>TJB 3</b>	222	349	130	125	130	214	300
<b>TJB 4</b>	252	407	162	150	135	243	360
<b>TJB 5</b>	298	455	192	162	157	298	405

#### FORMATO DE PEDIDO

Tobera de largo alcance, orientable manualmente tipo TJB 1.  
Acabado lacado blanco similar a RAL 9016.

**Formato de pedido:**

TJB

1

BL

# SERIE T

TJB

Tabla de Selección

## Leyenda:

Q = Caudal

Ak = Area efectiva en m<sup>2</sup>

X = Alcance en m. para velocidad final Vz en m/s

Pt = Pérdida de carga en Pa

LwA = Potencia sonora en dB(A)

## DESCARGA HORIZONTAL

Q (m <sup>3</sup> /h) (l/s)	Tamaño	1	2	3	4	5
	Ak	0,004	0,008	0,013	0,020	0,028
<b>100</b> 27,8	Vk X para Vz=0,25 X para Vz=0,50 X para Vz=1,0 Pt LwA	7,2 12,6 6,3 3,2 27 < 10	3,5 8,8 4,4 2,2 6 < 10			
<b>150</b> 41,7	Vk X para Vz=0,25 X para Vz=0,50 X para Vz=1,0 Pt LwA	10,8 18,9 9,5 4,7 61 22	5,3 13,2 6,6 3,3 15 < 10	3,1 10,2 5,1 2,5 5 < 10	2,1 8,3 4,1 2,1 2 < 10	
<b>200</b> 55,6	Vk X para Vz=0,25 X para Vz=0,50 X para Vz=1,0 Pt LwA	14,4 25,2 12,6 6,3 108 30	7,1 17,6 8,8 4,4 26 11	4,2 13,6 6,8 3,4 9 < 10	2,8 11,0 5,5 2,8 4 < 10	
<b>300</b> 83,3	Vk X para Vz=0,25 X para Vz=0,50 X para Vz=1,0 Pt LwA	21,7 37,8 18,9 9,5 243 43	10,6 26,5 13,2 6,6 58 23	6,3 20,4 10,2 5,1 20 11	4,1 16,5 8,3 4,1 9 < 10	
<b>400</b> 111,1	Vk X para Vz=0,25 X para Vz=0,50 X para Vz=1,0 Pt LwA	28,9 50,4 25,2 12,6 432 51	4,1 35,3 17,6 8,8 104 32	8,4 27,1 13,6 6,8 36 19	5,5 22,1 11,0 5,5 16 < 10	3,9 18,6 9,3 4,6 8 < 10
<b>500</b> 138,9	Vk X para Vz=0,25 X para Vz=0,50 X para Vz=1,0 Pt LwA		17,7 44,1 22,1 11,0 162 39	10,5 33,9 17,0 8,5 57 25	6,9 27,6 13,8 6,9 25 15	4,9 23,2 11,6 5,8 12 < 10
<b>600</b> 166,7	Vk X para Vz=0,25 X para Vz=0,50 X para Vz=1,0 Pt LwA		21,2 52,9 26,5 13,2 233 44	12,6 40,7 20,4 10,2 82 31	8,3 33,1 16,5 8,3 36 20	5,9 27,9 13,9 7,0 18 11
<b>800</b> 222,2	Vk X para Vz=0,25 X para Vz=0,50 X para Vz=1,0 Pt LwA		28,3 70,6 35,3 17,6 415 53	16,7 54,3 27,1 13,6 145 39	11,1 44,1 22,1 11,0 63 28	7,8 37,1 18,6 9,3 32 20
<b>1000</b> 277,8	Vk X para Vz=0,25 X para Vz=0,50 X para Vz=1,0 Pt LwA			20,9 67,8 33,9 17,0 227 45	13,8 55,1 27,6 13,8 99 35	9,8 46,4 23,2 11,6 50 26
<b>1250</b> 347,2	Vk X para Vz=0,25 X para Vz=0,50 X para Vz=1,0 Pt LwA				17,3 68,9 34,5 17,2 155 41	12,2 58,0 29,0 14,5 78 33
<b>1500</b> 416,7	Vk X para Vz=0,25 X para Vz=0,50 X para Vz=1,0 Pt LwA				20,7 82,7 41,3 20,7 223 47	14,7 69,6 34,8 17,4 112 38
<b>2000</b> 555,6	Vk X para Vz=0,25 X para Vz=0,50 X para Vz=1,0 Pt LwA					19,6 92,8 46,4 23,2 199 47

## SERIE T

TJB

## Tabla de Selección

## Leyenda:

Q = Caudal

Ak = Area efectiva en m<sup>2</sup>

Vk = Velocidad efectiva en m/s

Y = Alcance en m. para velocidad final 0,25 m/s.  $\Delta T = \text{ } ^\circ\text{C}$ .

Pt = Pérdida de carga en Pa

LwA = Potencia sonora en dB(A)

## DESCARGA VERTICAL

Q (m <sup>3</sup> /h) (l/s)	Tamaño	1	2	3	4	5
	Ak	0,004	0,008	0,013	0,020	0,028
100 27,8	Vk	7,2	3,5			
	Y ( $\Delta T = 5^\circ\text{C}$ )	8,4	4,9			
	Y ( $\Delta T = 10^\circ\text{C}$ )	6,0	3,5			
	Y ( $\Delta T = 20^\circ\text{C}$ )	4,2	2,5			
	Pt	27	6			
	LwA	< 10	< 10			
150 41,7	Vk	10,8	5,3	3,1	2,1	
	Y ( $\Delta T = 5^\circ\text{C}$ )	12,7	7,4	5,0	3,7	
	Y ( $\Delta T = 10^\circ\text{C}$ )	9,0	5,2	3,5	2,6	
	Y ( $\Delta T = 20^\circ\text{C}$ )	6,3	3,7	2,5	1,8	
	Pt	61	15	5	2	
	LwA	22	< 10	< 10	< 10	
200 55,6	Vk	14,4	7,1	4,2	2,8	
	Y ( $\Delta T = 5^\circ\text{C}$ )	16,9	9,9	6,7	4,9	
	Y ( $\Delta T = 10^\circ\text{C}$ )	11,9	7,0	4,7	3,5	
	Y ( $\Delta T = 20^\circ\text{C}$ )	8,4	4,9	3,3	2,4	
	Pt	108	26	9	4	
	LwA	30	11	< 10	< 10	
300 83,3	Vk	21,7	10,6	6,3	4,1	
	Y ( $\Delta T = 5^\circ\text{C}$ )	25,3	14,8	10,0	7,3	
	Y ( $\Delta T = 10^\circ\text{C}$ )	17,9	10,5	7,1	5,2	
	Y ( $\Delta T = 20^\circ\text{C}$ )	12,7	7,4	5,0	3,7	
	Pt	243	58	20	9	
	LwA	43	23	11	< 10	
400 111,1	Vk	28,9	14,1	8,4	5,5	
	Y ( $\Delta T = 5^\circ\text{C}$ )	33,8	19,8	13,3	9,8	
	Y ( $\Delta T = 10^\circ\text{C}$ )	23,9	14,0	9,4	6,9	
	Y ( $\Delta T = 20^\circ\text{C}$ )	16,9	9,9	6,7	4,9	
	Pt	432	104	36	16	
	LwA	51	32	19	< 10	
500 138,9	Vk		17,7	10,5	6,9	4,9
	Y ( $\Delta T = 5^\circ\text{C}$ )		24,7	16,7	12,2	9,4
	Y ( $\Delta T = 10^\circ\text{C}$ )		17,5	11,8	8,6	6,7
	Y ( $\Delta T = 20^\circ\text{C}$ )		12,4	8,3	6,1	4,7
	Pt		162	57	25	12
	LwA		39	25	15	< 10
600 166,7	Vk		21,2	12,6	8,3	5,9
	Y ( $\Delta T = 5^\circ\text{C}$ )		29,7	20,0	14,7	11,3
	Y ( $\Delta T = 10^\circ\text{C}$ )		21,0	14,2	10,4	8,0
	Y ( $\Delta T = 20^\circ\text{C}$ )		14,8	10,0	7,3	5,7
	Pt		233	82	36	18
	LwA		44	31	20	11
800 222,2	Vk		28,3	16,7	11,1	7,8
	Y ( $\Delta T = 5^\circ\text{C}$ )		39,6	26,7	19,5	15,1
	Y ( $\Delta T = 10^\circ\text{C}$ )		28,0	18,9	13,8	10,7
	Y ( $\Delta T = 20^\circ\text{C}$ )		19,8	13,3	9,8	7,6
	Pt		415	145	63	32
	LwA		53	39	28	20
1000 277,8	Vk			20,9	13,8	9,8
	Y ( $\Delta T = 5^\circ\text{C}$ )			33,4	24,4	18,9
	Y ( $\Delta T = 10^\circ\text{C}$ )			23,6	17,3	13,4
	Y ( $\Delta T = 20^\circ\text{C}$ )			16,7	12,2	9,4
	Pt			227	99	50
	LwA			45	35	26
1250 347,2	Vk				17,3	12,2
	Y ( $\Delta T = 5^\circ\text{C}$ )				30,5	23,6
	Y ( $\Delta T = 10^\circ\text{C}$ )				21,6	16,7
	Y ( $\Delta T = 20^\circ\text{C}$ )				15,3	11,8
	Pt				155	78
	LwA				41	33
1500 416,7	Vk				20,7	14,7
	Y ( $\Delta T = 5^\circ\text{C}$ )				36,7	28,3
	Y ( $\Delta T = 10^\circ\text{C}$ )				25,9	20,0
	Y ( $\Delta T = 20^\circ\text{C}$ )				18,3	14,2
	Pt				223	112
	LwA				47	38
2000 555,6	Vk					19,6
	Y ( $\Delta T = 5^\circ\text{C}$ )					37,8
	Y ( $\Delta T = 10^\circ\text{C}$ )					26,7
	Y ( $\Delta T = 20^\circ\text{C}$ )					18,9
	Pt					199
	LwA					47

# SERIE T

TJNT



## TOBERA DE LARGO ALCANCE TERMOSTÁTICA

Modelo **TJNT**. Tobera de largo alcance para impulsión de aire, orientable en múltiples direcciones, con ángulo límite de  $\pm 30^\circ$ , con actuador termostático.

La tobera TJNT se caracteriza por su regulación automática mediante un actuador termostático, gracias al efecto térmico de memoria de la aleación formada por el Níquel-Titanio.

Cuando el aire introducido está caliente (condición de calentamiento), el actuador moverá el flujo hacia abajo. Por el contrario, cuando el aire introducido es frío (condición de enfriamiento), el actuador moverá el flujo horizontalmente, siguiendo el ángulo de deflexión establecido previamente.

Fabricado en aluminio.  
Acabado estándar en aluminio natural satinado.

### TJNT

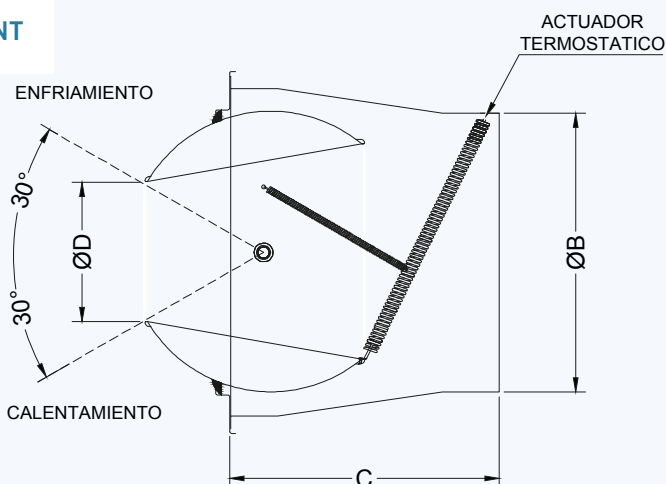

### TJNT

Condición de enfriamiento



### TJNT

Condición de calentamiento



	Ø D	Ø B	C
TJNT 150	150	298	285
TJNT 200	200	398	290
TJNT 230	230	398	290

### FORMATO DE PEDIDO

Tobera de largo alcance, con actuador termostático tipo TJNT 150.  
Acabado aluminio natural satinado.

Formato de pedido:

TJNT

150

AL

# SERIE T

## TJNT

### Tabla de Selección

**Leyenda:**

Q = Caudal

Ak = Area efectiva en m<sup>2</sup>

Vk = Velocidad efectiva en m/s

X = Alcance en m. para velocidad final 0,25 m/s

Pt = Pérdida de carga en Pa

LwA = Potencia sonora en dB(A)

	Tamaño	150	200	230
<b>Q</b> (m <sup>3</sup> /h) (l/s)	<b>Ak</b>	0,018	0,031	0,042
<b>400</b> 111,1	Vk X Pt LwA	6,3 21,8 25 16		
<b>600</b> 166,7	Vk X Pt LwA	9,4 25,4 56 27		
<b>800</b> 222,2	Vk X Pt LwA	12,6 27,9 100 34	7,1 25,3 32 17	
<b>1000</b> 277,8	Vk X Pt LwA	15,7 29,9 155 40	8,8 27,3 50 23	6,7 27,9 29 18
<b>1250</b> 347,2	Vk X Pt LwA	19,6 31,9 242 46	11,1 29,3 77 30	8,4 30,0 44 25
<b>1500</b> 416,7	Vk X Pt LwA	23,6 33,5 347 50	13,3 30,9 111 36	10,0 31,8 64 30
<b>1750</b> 486,1	Vk X Pt LwA		15,5 32,3 150 40	11,7 33,2 86 35
<b>2000</b> 555,6	Vk X Pt LwA		17,7 33,4 196 44	13,4 34,5 113 40
<b>2250</b> 625,0	Vk X Pt LwA		19,9 34,5 248 48	15,0 35,6 142 43

# SERIE T

TO



## TOBERA DE LARGO ALCANCE ORIENTABLE

- Modelo **TO**. Tobera de largo alcance orientable manualmente.  
Modelo **TO-C**. Conjunto de toberas de largo alcance acoplable a conducto.  
Modelo **TO-R**. Conjunto de toberas de largo alcance con marco de rejilla.

Fabricada en ABS.  
Acabados estándar en colores blanco y gris. Negro (opcional).

### Sistemas de fijación:

- (C)** Clip (opcional)  
Dimensiones de hueco (A-25) x (B-25)
- (T)** Tornillo visible (opcional)  
Dimensiones de hueco (A-39) x (B-39)
- (-)** Sin fijación (estándar)  
Dimensiones de hueco (A-39) x (B-39)

### Accesorios:

- (MM)** Marco de montaje para TO-R  
Dimensiones de hueco  
para clip (C) (A-25) x (B-25)

TO

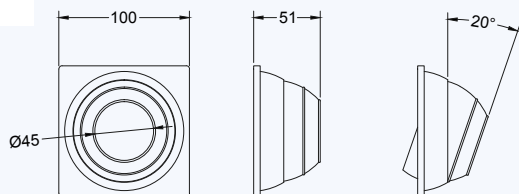

TO-C

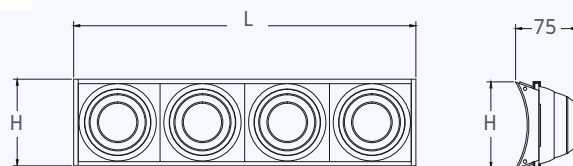

TO-R 1

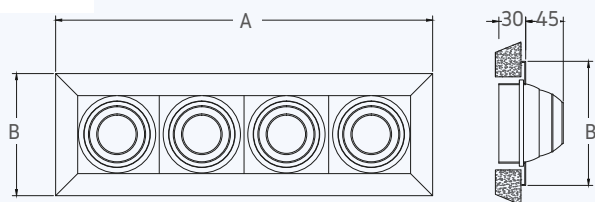

TO-R 2

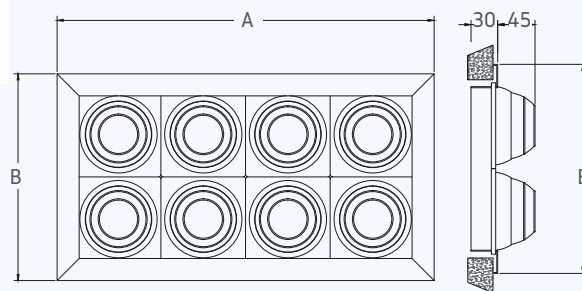

TO-R 3

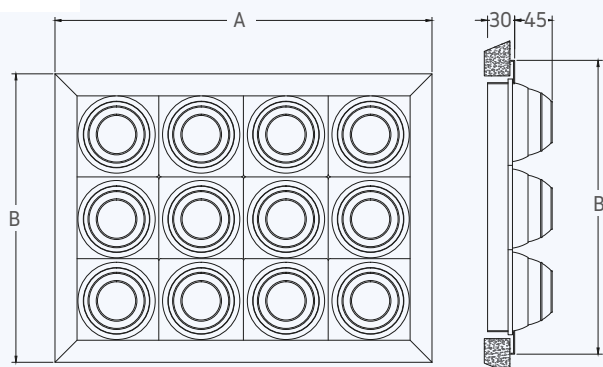



## SERIE T

TO

## Tabla de Selección

## Leyenda:

Q = Caudal

Ak = Area efectiva en m<sup>2</sup>X = Alcance en m. para velocidad  
final Vz en m/s

Pt = Pérdida de carga en Pa

LwA = Potencia sonora en dB(A)

## TABLA CORRECCIÓN Nº FILAS DE TOBERAS

	2 Filas	3 Filas
Q	x 2	x 3
Vk	x 1	x 1
X	x 1,41	x 1,73
Pt	x 1	x 1
LwA	+ 3	+ 4,8

## DESCARGA HORIZONTAL

Q (m <sup>3</sup> /h)/tobera	Nº de toberas	1	2	3	4	5	6	7	8	9	10
	Tamaño	1x1	1x2	1x3	1x4	1x5	1x6	1x7	1x8	1x9	1x10
40 (m <sup>3</sup> /h)/tobera	Q (m <sup>3</sup> /h) conjunto	40	80	120	160	200	240	280	320	360	400
	Vk X para Vz=0,25 X para Vz=0,50 X para Vz=1,0 Pt LwA	7,0 5,8 2,9 1,4 33 < 10	7,0 8,2 4,1 2,0 33 11	7,0 10,0 5,0 2,5 33 13	7,0 11,6 5,8 2,9 33 14	7,0 13,0 6,5 3,2 33 15	7,0 14,2 7,1 3,5 33 16	7,0 15,3 7,7 3,8 33 17	7,0 16,4 8,2 4,1 33 17	7,0 17,4 8,7 4,3 33 18	7,0 18,3 9,2 4,6 33 18
50 (m <sup>3</sup> /h)/tobera	Q (m <sup>3</sup> /h) conjunto	50	100	150	200	250	300	350	400	450	500
	Vk X para Vz=0,25 X para Vz=0,50 X para Vz=1,0 Pt LwA	8,7 7,2 3,6 1,8 51 14	8,7 10,2 5,1 2,6 51 17	8,7 12,5 6,3 3,1 51 19	8,7 14,5 7,2 3,6 51 20	8,7 16,2 8,1 4,0 51 21	8,7 17,7 8,9 4,4 51 22	8,7 19,2 9,6 4,8 51 22	8,7 20,5 10,2 5,1 51 23	8,7 21,7 10,9 5,4 51 24	8,7 22,9 11,4 5,7 51 24
60 (m <sup>3</sup> /h)/tobera	Q (m <sup>3</sup> /h) conjunto	60	120	180	240	300	360	420	480	540	600
	Vk X para Vz=0,25 X para Vz=0,50 X para Vz=1,0 Pt LwA	10,5 8,7 4,3 2,2 74 19	10,5 12,3 6,1 3,1 74 22	10,5 15,0 7,5 3,8 74 24	10,5 17,4 8,7 4,3 74 25	10,5 19,4 9,7 4,9 74 26	10,5 21,3 10,6 5,3 74 27	10,5 23,0 11,5 5,7 74 27	10,5 24,6 12,3 6,1 74 28	10,5 26,1 13,0 6,5 74 28	10,5 27,5 13,7 6,9 74 29
70 (m <sup>3</sup> /h)/tobera	Q (m <sup>3</sup> /h) conjunto	70	140	210	280	350	420	490	560	630	700
	Vk X para Vz=0,25 X para Vz=0,50 X para Vz=1,0 Pt LwA	12,2 10,1 5,1 2,5 101 23	12,2 14,3 7,2 3,6 101 26	12,2 17,6 8,8 4,4 101 28	12,2 20,3 10,1 5,1 101 29	12,2 22,7 11,3 5,7 101 30	12,2 24,8 12,4 6,2 101 31	12,2 26,8 13,4 6,7 101 31	12,2 28,7 14,3 7,2 101 32	12,2 30,4 15,2 7,6 101 32	12,2 32,1 16,0 8,0 101 33
80 (m <sup>3</sup> /h)/tobera	Q (m <sup>3</sup> /h) conjunto	80	160	240	320	400	480	560	640	720	800
	Vk X para Vz=0,25 X para Vz=0,50 X para Vz=1,0 Pt LwA	14,0 11,6 5,8 2,9 132 26	14,0 16,4 8,2 4,1 132 29	14,0 20,1 10,0 5,0 132 31	14,0 23,2 11,6 5,8 132 32	14,0 25,9 13,0 6,5 132 33	14,0 28,4 14,2 7,1 132 34	14,0 30,7 15,3 7,7 132 35	14,0 32,8 16,4 8,2 132 35	14,0 34,8 17,4 8,7 132 36	14,0 36,6 18,3 9,2 132 36
90 (m <sup>3</sup> /h)/tobera	Q (m <sup>3</sup> /h) conjunto	90	180	270	360	450	540	630	720	810	900
	Vk X para Vz=0,25 X para Vz=0,50 X para Vz=1,0 Pt LwA	15,7 13,0 6,5 3,3 167 30	15,7 18,4 9,2 4,6 167 33	15,7 22,6 11,3 5,6 167 34	15,7 26,1 13,0 6,5 167 36	15,7 29,1 14,6 7,3 167 37	15,7 31,9 16,0 8,0 167 37	15,7 34,5 17,2 8,6 167 38	15,7 36,9 18,4 9,2 167 39	15,7 39,1 19,6 9,8 167 39	15,7 41,2 20,6 10,3 167 40
100 (m <sup>3</sup> /h)/tobera	Q (m <sup>3</sup> /h) conjunto	100	200	300	400	500	600	700	800	900	1000
	Vk X para Vz=0,25 X para Vz=0,50 X para Vz=1,0 Pt LwA	17,5 14,5 7,2 3,6 206 32	17,5 20,5 10,2 5,1 206 35	17,5 25,1 12,5 6,3 206 37	17,5 29,0 14,5 7,2 206 38	17,5 32,4 16,2 8,1 206 39	17,5 35,5 17,7 8,9 206 40	17,5 38,3 19,2 9,6 206 41	17,5 41,0 20,5 10,2 206 41	17,5 43,4 21,7 10,9 206 42	17,5 45,8 22,9 11,4 206 42
110 (m <sup>3</sup> /h)/tobera	Q (m <sup>3</sup> /h) conjunto	110	220	330	440	550	660	770	880	990	1100
	Vk X para Vz=0,25 X para Vz=0,50 X para Vz=1,0 Pt LwA	19,2 15,9 8,0 4,0 249 35	19,2 22,5 11,3 5,6 249 38	19,2 27,6 13,8 6,9 249 40	19,2 31,9 15,9 8,0 249 41	19,2 35,6 17,8 8,9 249 42	19,2 39,0 19,5 9,8 249 43	19,2 42,1 21,1 10,5 249 43	19,2 45,1 22,5 11,3 249 44	19,2 47,8 23,9 11,9 249 44	19,2 50,4 25,2 12,6 249 45

# SERIE T

TO

## Tabla de Selección

### Leyenda:

Q = Caudal  
 Vk = Velocidad efectiva en m/s  
 Y = Alcance en m. para velocidad final 0,25 m/s.  $\Delta T = \text{ } ^\circ\text{C}$ .  
 Pt = Pérdida de carga en Pa  
 LwA = Potencia sonora en dB(A)

### TABLA CORRECCIÓN N° FILAS DE TOBERAS

	2 Filas	3 Filas
Q	x 2	x 3
Vk	x 1	x 1
X	x 1,41	x 1,73
Pt	x 1	x 1
LwA	+ 3	+ 4,8

TOBERAS Y  
MULTITOBERAS

### DESCARGA VERTICAL

Q (m <sup>3</sup> /h)/tobera	N° de toberas	1	2	3	4	5	6	7	8	9	10
	Tamaño	1x1	1x2	1x3	1x4	1x5	1x6	1x7	1x8	1x9	1x10
40 (m <sup>3</sup> /h)/tobera	Q (m <sup>3</sup> /h) conjunto	40	80	120	160	200	240	280	320	360	400
	Vk	7,0	7,0	7,0	7,0	7,0	7,0	7,0	7,0	7,0	7,0
	Y ( $\Delta T = 5^\circ\text{C}$ )	5,6	6,7	7,4	8,0	8,4	8,8	9,2	9,5	9,8	10,0
	Y ( $\Delta T = 10^\circ\text{C}$ )	4,0	4,7	5,2	5,6	6,0	6,2	6,5	6,7	6,9	7,1
	Y ( $\Delta T = 20^\circ\text{C}$ )	2,8	3,3	3,7	4,0	4,2	4,4	4,6	4,7	4,9	5,0
	Pt	33	33	33	33	33	33	33	33	33	33
LwA	< 10	11	13	14	15	16	17	17	18	18	
50 (m <sup>3</sup> /h)/tobera	Q (m <sup>3</sup> /h) conjunto	50	100	150	200	250	300	350	400	450	500
	Vk	8,7	8,7	8,7	8,7	8,7	8,7	8,7	8,7	8,7	8,7
	Y ( $\Delta T = 5^\circ\text{C}$ )	7,0	8,4	9,3	10,0	10,5	11,0	11,5	11,8	12,2	12,5
	Y ( $\Delta T = 10^\circ\text{C}$ )	5,0	5,9	6,6	7,0	7,4	7,8	8,1	8,4	8,6	8,9
	Y ( $\Delta T = 20^\circ\text{C}$ )	3,5	4,2	4,6	5,0	5,3	5,5	5,7	5,9	6,1	6,3
	Pt	51	51	51	51	51	51	51	51	51	51
LwA	14	17	19	20	21	22	22	23	24	24	
60 (m <sup>3</sup> /h)/tobera	Q (m <sup>3</sup> /h) conjunto	60	120	180	240	300	360	420	480	540	600
	Vk	10,5	10,5	10,5	10,5	10,5	10,5	10,5	10,5	10,5	10,5
	Y ( $\Delta T = 5^\circ\text{C}$ )	8,5	10,0	11,1	12,0	12,6	13,2	13,7	14,2	14,6	15,0
	Y ( $\Delta T = 10^\circ\text{C}$ )	6,0	7,1	7,9	8,5	8,9	9,4	9,7	10,0	10,3	10,6
	Y ( $\Delta T = 20^\circ\text{C}$ )	4,2	5,0	5,6	6,0	6,3	6,6	6,9	7,1	7,3	7,5
	Pt	74	74	74	74	74	74	74	74	74	74
LwA	19	22	24	25	26	27	27	28	28	29	
70 (m <sup>3</sup> /h)/tobera	Q (m <sup>3</sup> /h) conjunto	70	140	210	280	350	420	490	560	630	700
	Vk	12,2	12,2	12,2	12,2	12,2	12,2	12,2	12,2	12,2	12,2
	Y ( $\Delta T = 5^\circ\text{C}$ )	9,9	11,7	13,0	13,9	14,7	15,4	16,0	16,6	17,1	17,5
	Y ( $\Delta T = 10^\circ\text{C}$ )	7,0	8,3	9,2	9,9	10,4	10,9	11,3	11,7	12,1	12,4
	Y ( $\Delta T = 20^\circ\text{C}$ )	4,9	5,9	6,5	7,0	7,4	7,7	8,0	8,3	8,5	8,8
	Pt	101	101	101	101	101	101	101	101	101	101
LwA	23	26	28	29	30	31	31	32	32	33	
80 (m <sup>3</sup> /h)/tobera	Q (m <sup>3</sup> /h) conjunto	80	160	240	320	400	480	560	640	720	800
	Vk	14,0	14,0	14,0	14,0	14,0	14,0	14,0	14,0	14,0	14,0
	Y ( $\Delta T = 5^\circ\text{C}$ )	11,3	13,4	14,8	15,9	16,8	17,6	18,3	18,9	19,5	20,0
	Y ( $\Delta T = 10^\circ\text{C}$ )	8,0	9,5	10,5	11,3	11,9	12,5	13,0	13,4	13,8	14,2
	Y ( $\Delta T = 20^\circ\text{C}$ )	5,6	6,7	7,4	8,0	8,4	8,8	9,2	9,5	9,8	10,0
	Pt	132	132	132	132	132	132	132	132	132	132
LwA	26	29	31	32	33	34	35	35	36	36	
90 (m <sup>3</sup> /h)/tobera	Q (m <sup>3</sup> /h) conjunto	90	180	270	360	450	540	630	720	810	900
	Vk	15,7	15,7	15,7	15,7	15,7	15,7	15,7	15,7	15,7	15,7
	Y ( $\Delta T = 5^\circ\text{C}$ )	12,7	15,1	16,7	17,9	19,0	19,8	20,6	21,3	22,0	22,5
	Y ( $\Delta T = 10^\circ\text{C}$ )	9,0	10,7	11,8	12,7	13,4	14,0	14,6	15,1	15,5	15,9
	Y ( $\Delta T = 20^\circ\text{C}$ )	6,3	7,5	8,3	9,0	9,5	9,9	10,3	10,7	11,0	11,3
	Pt	167	167	167	167	167	167	167	167	167	167
LwA	30	33	34	36	37	37	38	39	39	40	
100 (m <sup>3</sup> /h)/tobera	Q (m <sup>3</sup> /h) conjunto	100	200	300	400	500	600	700	800	900	1000
	Vk	17,5	17,5	17,5	17,5	17,5	17,5	17,5	17,5	17,5	17,5
	Y ( $\Delta T = 5^\circ\text{C}$ )	14,1	16,7	18,5	19,9	21,1	22,0	22,9	23,7	24,4	25,0
	Y ( $\Delta T = 10^\circ\text{C}$ )	8,0	11,4	13,9	16,1	18,0	19,7	21,2	22,7	24,1	25,4
	Y ( $\Delta T = 20^\circ\text{C}$ )	7,0	8,4	9,3	10,0	10,5	11,0	11,5	11,8	12,2	12,5
	Pt	206	206	206	206	206	206	206	206	206	206
LwA	32	35	37	38	39	40	41	41	42	42	
110 (m <sup>3</sup> /h)/tobera	Q (m <sup>3</sup> /h) conjunto	110	220	330	440	550	660	770	880	990	1100
	Vk	19,2	19,2	19,2	19,2	19,2	19,2	19,2	19,2	19,2	19,2
	Y ( $\Delta T = 5^\circ\text{C}$ )	15,5	18,4	20,4	21,9	23,2	24,2	25,2	26,1	26,8	27,6
	Y ( $\Delta T = 10^\circ\text{C}$ )	11,0	13,0	14,4	15,5	16,4	17,1	17,8	18,4	19,0	19,5
	Y ( $\Delta T = 20^\circ\text{C}$ )	7,7	9,2	10,2	11,0	11,6	12,1	12,6	13,0	13,4	13,8
	Pt	249	249	249	249	249	249	249	249	249	249
LwA	35	38	40	41	42	43	43	44	44	45	
150 (m <sup>3</sup> /h)/tobera	Q (m <sup>3</sup> /h) conjunto	150	300	450	600	750	900	1050	1200	1350	1500
	Vk	26,2	26,2	26,2	26,2	26,2	26,2	26,2	26,2	26,2	26,2
	Y ( $\Delta T = 5^\circ\text{C}$ )	21,1	25,1	27,8	29,9	31,6	33,1	34,4	35,5	36,6	37,6
	Y ( $\Delta T = 10^\circ\text{C}$ )	14,9	17,8	19,7	21,1	22,3	23,4	24,3	25,1	25,9	26,6
	Y ( $\Delta T = 20^\circ\text{C}$ )	10,6	12,6	13,9	14,9	15,8	16,5	17,2	17,8	18,3	18,8
	Pt	463	463	463	463	463	463	463	463	463	463
LwA	43	46	48	49	50	51	52	52	53	53	

# SERIE T

TF

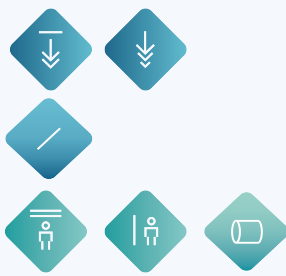

## TOBERA DE LARGO ALCANCE FIJA

- Modelo **TF**. Tobera de largo alcance fija.  
 Modelo **TF-C**. Conjunto de toberas de largo alcance acoplable a conducto.  
 Modelo **TF-R**. Conjunto de toberas de largo alcance con marco de rejilla.

Fabricada en ABS.  
 Acabado estándar en color blanco.

### Sistemas de fijación:

- (C)** Clip (opcional)  
Dimensiones de hueco (A-25) x (B-25)
- (T)** Tornillo visible (opcional)  
Dimensiones de hueco (A-39) x (B-39)
- (-)** Sin fijación (Eestándar)  
Dimensiones de hueco (A-39) x (B-39)

### Accesorios:

- (MM)** Marco de montaje para TF-R  
Dimensiones de hueco  
para clip (C) (A-25) x (B-25)

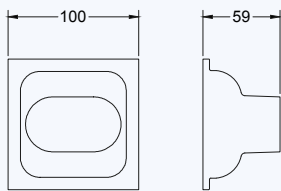
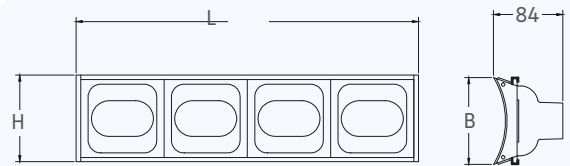
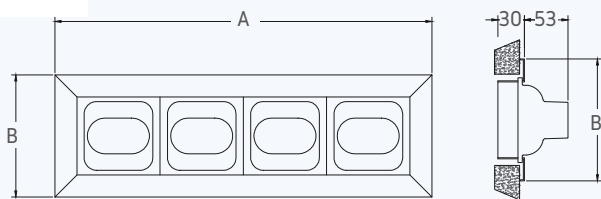
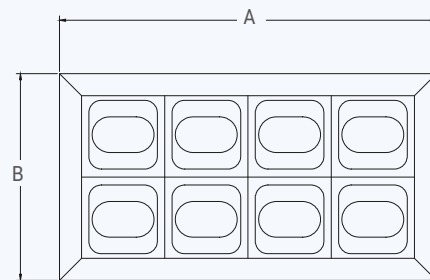
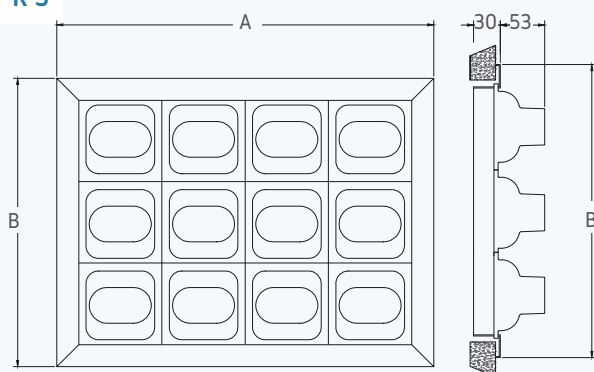
**TF****TF-C****TF-R 1****TF-R 2****TF-R 3**

# SERIE T

TO-R - TF-R  
TO-C - TF-C

Tabla de Selección

## TO-R - TF-R

### DIMENSIONES NOMINALES NORMALIZADAS

Nº por fila	3	4	5	6	7	8	9	10
A	345	445	545	645	745	845	945	1045
B TO -R 1x_ / TF-R 1x_				145				
B TO -R 2x_ / TF-R 2x_				247				
B TO -R 3x_ / TF-R 3x_				349				

## TO-C - TF-C

### DIMENSIONES NOMINALES NORMALIZADAS

Nº por fila	3	4	5	6	7	8	9	10
L	320	420	520	620	720	820	920	1020
H				117				

## TO-C - TF-C

### REMATES

TR	Tapa de conducto rectangular
TD15	Tapa de conducto Ø 150 a 250
TD30	Tapa de conducto Ø 300 a 600

## Ejemplo de dimensión

### TO-C 1x5

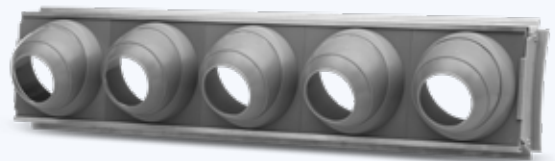

## SERIE T

TF

## Tabla de Selección

## Leyenda:

Q = Caudal

Ak = Area efectiva en m<sup>2</sup>

X = Alcance en m. para velocidad

final Vz en m/s

Pt = Pérdida de carga en Pa

LwA = Potencia sonora en dB(A)

TABLA CORRECCIÓN N° FILAS DE TOBERAS

	2 Filas	3 Filas
Q	x 2	x 3
Vk	x 1	x 1
X	x 1,41	x 1,73
Pt	x 1	x 1
LwA	+ 3	+ 4,8

## DESCARGA HORIZONTAL

Q (m <sup>3</sup> /h)/tobera	N° de toberas	1	2	3	4	5	6	7	8	9	10
		Tamaño	1x1	1x2	1x3	1x4	1x5	1x6	1x7	1x8	1x9
75 (m <sup>3</sup> /h)/tobera	Q (m <sup>3</sup> /h) conjunto	75	150	225	300	375	450	525	600	675	750
	Vk X para Vz=0,25 X para Vz=0,50 X para Vz=1,0 Pt LwA	7,8 8,4 4,2 2,1 4,4 15	7,8 11,8 5,9 3,0 4,4 18	7,8 14,5 7,2 3,6 4,4 20	7,8 16,7 8,4 4,2 4,4 21	7,8 18,7 9,3 4,7 4,4 22	7,8 20,5 10,2 5,1 4,4 23	7,8 22,1 11,1 5,5 4,4 23	7,8 23,6 11,8 5,9 4,4 24	7,8 25,1 12,5 6,3 4,4 24	7,8 26,4 13,2 6,6 4,4 24
100 (m <sup>3</sup> /h)/tobera	Q (m <sup>3</sup> /h) conjunto	100	200	300	400	500	600	700	800	900	1000
	Vk X para Vz=0,25 X para Vz=0,50 X para Vz=1,0 Pt LwA	10,3 11,1 5,6 2,8 7,9 23	10,3 15,8 7,9 3,9 7,9 26	10,3 19,3 9,7 4,8 7,9 28	10,3 22,3 11,1 5,6 7,9 29	10,3 24,9 12,5 6,2 7,9 30	10,3 27,3 13,6 6,8 7,9 31	10,3 29,5 14,7 7,4 7,9 32	10,3 31,5 15,8 7,9 7,9 32	10,3 33,4 16,7 8,4 7,9 33	10,3 35,2 17,6 8,8 7,9 33
125 (m <sup>3</sup> /h)/tobera	Q (m <sup>3</sup> /h) conjunto	125	250	375	500	625	750	875	1000	1125	1250
	Vk X para Vz=0,25 X para Vz=0,50 X para Vz=1,0 Pt LwA	12,9 13,9 7,0 3,5 12,3 30	12,9 19,7 9,9 4,9 12,3 33	12,9 24,1 12,1 6,0 12,3 34	12,9 27,9 13,9 7,0 12,3 36	12,9 31,2 15,6 7,8 12,3 37	12,9 34,1 17,1 8,5 12,3 37	12,9 36,9 18,4 9,2 12,3 38	12,9 39,4 19,7 9,9 12,3 39	12,9 41,8 20,9 10,4 12,3 39	12,9 44,1 22,0 11,0 12,3 40
150 (m <sup>3</sup> /h)/tobera	Q (m <sup>3</sup> /h) conjunto	150	300	450	600	750	900	1050	1200	1350	1500
	Vk X para Vz=0,25 X para Vz=0,50 X para Vz=1,0 Pt LwA	15,5 16,7 8,4 4,2 17,7 35	15,5 23,6 11,8 5,9 17,7 38	15,5 29,0 14,5 7,2 17,7 40	15,5 33,4 16,7 8,4 17,7 41	15,5 37,4 18,7 9,3 17,7 42	15,5 40,9 20,5 10,2 17,7 43	15,5 44,2 22,1 11,1 17,7 43	15,5 47,3 23,6 11,8 17,7 44	15,5 50,2 25,1 12,5 17,7 45	15,5 52,9 26,4 13,2 17,7 45
175 (m <sup>3</sup> /h)/tobera	Q (m <sup>3</sup> /h) conjunto	175	350	525	700	875	1050	1225	1400	1575	1750
	Vk X para Vz=0,25 X para Vz=0,50 X para Vz=1,0 Pt LwA	18,1 19,5 9,8 4,9 24,1 39	18,1 27,6 13,8 6,9 24,1 42	18,1 33,8 16,9 8,4 24,1 44	18,1 39,0 19,5 9,8 24,1 45	18,1 43,6 21,8 10,9 24,1 46	18,1 47,8 23,9 11,9 24,1 47	18,1 51,6 25,8 12,9 24,1 48	18,1 55,2 27,6 13,8 24,1 49	18,1 58,5 29,3 14,6 24,1 49	18,1 61,7 30,8 15,4 24,1 49
200 (m <sup>3</sup> /h)/tobera	Q (m <sup>3</sup> /h) conjunto	200	400	600	800	1000	1200	1400	1600	1800	2000
	Vk X para Vz=0,25 X para Vz=0,50 X para Vz=1,0 Pt LwA	20,7 22,3 11,1 5,6 31,4 43	20,7 31,5 15,8 7,9 31,4 46	20,7 38,6 19,3 9,7 31,4 48	20,7 44,6 22,3 11,1 31,4 49	20,7 49,8 24,9 12,5 31,4 50	20,7 54,6 27,3 13,6 31,4 51	20,7 59,0 29,5 14,7 31,4 52	20,7 63,0 31,5 15,8 31,4 52	20,7 66,9 33,4 16,7 31,4 53	20,7 70,5 35,2 17,6 31,4 53
225 (m <sup>3</sup> /h)/tobera	Q (m <sup>3</sup> /h) conjunto	225	450	675	900	1125	1350	1575	1800	2025	2250
	Vk X para Vz=0,25 X para Vz=0,50 X para Vz=1,0 Pt LwA	23,3 25,1 12,5 6,3 398 47	23,3 35,5 17,7 8,9 398 50	23,3 43,4 21,7 10,9 398 52	23,3 50,2 25,1 12,5 398 53	23,3 56,1 28,0 14,0 398 54	23,3 61,4 30,7 15,4 398 55	23,3 66,3 33,2 16,6 398 55	23,3 70,9 35,5 17,7 398 56	23,3 75,2 37,6 18,8 398 56	23,3 79,3 39,6 19,8 398 57
250 (m <sup>3</sup> /h)/tobera	Q (m <sup>3</sup> /h) conjunto	250	500	750	1000	1250	1500	1750	2000	2250	2500
	Vk X para Vz=0,25 X para Vz=0,50 X para Vz=1,0 Pt LwA	25,8 27,9 13,9 7,0 491 50	25,8 39,4 19,7 9,9 491 53	25,8 48,3 24,1 12,1 491 55	25,8 55,7 27,9 13,9 491 56	25,8 62,3 31,2 15,6 491 57	25,8 68,2 34,1 17,1 491 58	25,8 73,7 36,9 18,4 491 58	25,8 78,8 39,4 19,7 491 59	25,8 83,6 41,8 20,9 491 59	25,8 88,1 44,1 22,0 491 60

# SERIE T

TF

Tabla de Selección

### Leyenda:

Q = Caudal  
 Vk = Velocidad efectiva en m/s  
 Y = Alcance en m. para velocidad final 0,25 m/s.  $\Delta T = \text{ } ^\circ\text{C}$ .  
 Pt = Pérdida de carga en Pa  
 LwA = Potencia sonora en dB(A)

### TABLA CORRECCIÓN Nº FILAS DE TOBERAS

	2 Filas	3 Filas
Q	x 2	x 3
Vk	x 1	x 1
X	x 1,19	x 1,32
Pt	x 1	x 1
LwA	+ 3	+ 4,8

TOBERAS Y  
MULTITOBERAS

### DESCARGA VERTICAL

Q (m³/h)/tobera	Nº de toberas	1	2	3	4	5	6	7	8	9	10
	Tamaño	1x1	1x2	1x3	1x4	1x5	1x6	1x7	1x8	1x9	1x10
<b>40</b> (m³/h)/tobera	Q (m³/h) conjunto	40	80	120	160	200	240	280	320	360	400
	Vk	7,0	7,0	7,0	7,0	7,0	7,0	7,0	7,0	7,0	7,0
	Y ( $\Delta T = 5^\circ\text{C}$ )	5,6	6,7	7,4	8,0	8,4	8,8	9,2	9,5	9,8	10,0
	Y ( $\Delta T = 10^\circ\text{C}$ )	4,0	4,7	5,2	5,6	6,0	6,2	6,5	6,7	6,9	7,1
	Y ( $\Delta T = 20^\circ\text{C}$ )	2,8	3,3	3,7	4,0	4,2	4,4	4,6	4,7	4,9	5,0
	Pt	33	33	33	33	33	33	33	33	33	33
LwA	< 10	11	13	14	15	16	17	17	18	18	
<b>50</b> (m³/h)/tobera	Q (m³/h) conjunto	50	100	150	200	250	300	350	400	450	500
	Vk	8,7	8,7	8,7	8,7	8,7	8,7	8,7	8,7	8,7	8,7
	Y ( $\Delta T = 5^\circ\text{C}$ )	7,0	8,4	9,3	10,0	10,5	11,0	11,5	11,8	12,2	12,5
	Y ( $\Delta T = 10^\circ\text{C}$ )	5,0	5,9	6,6	7,0	7,4	7,8	8,1	8,4	8,6	8,9
	Y ( $\Delta T = 20^\circ\text{C}$ )	3,5	4,2	4,6	5,0	5,3	5,5	5,7	5,9	6,1	6,3
	Pt	51	51	51	51	51	51	51	51	51	51
LwA	14	17	19	20	21	22	22	23	24	24	
<b>60</b> (m³/h)/tobera	Q (m³/h) conjunto	60	120	180	240	300	360	420	480	540	600
	Vk	10,5	10,5	10,5	10,5	10,5	10,5	10,5	10,5	10,5	10,5
	Y ( $\Delta T = 5^\circ\text{C}$ )	8,5	10,0	11,1	12,0	12,6	13,2	13,7	14,2	14,6	15,0
	Y ( $\Delta T = 10^\circ\text{C}$ )	6,0	7,1	7,9	8,5	8,9	9,4	9,7	10,0	10,3	10,6
	Y ( $\Delta T = 20^\circ\text{C}$ )	4,2	5,0	5,6	6,0	6,3	6,6	6,9	7,1	7,3	7,5
	Pt	74	74	74	74	74	74	74	74	74	74
LwA	19	22	24	25	26	27	27	28	28	29	
<b>70</b> (m³/h)/tobera	Q (m³/h) conjunto	70	140	210	280	350	420	490	560	630	700
	Vk	12,2	12,2	12,2	12,2	12,2	12,2	12,2	12,2	12,2	12,2
	Y ( $\Delta T = 5^\circ\text{C}$ )	9,9	11,7	13,0	13,9	14,7	15,4	16,0	16,6	17,1	17,5
	Y ( $\Delta T = 10^\circ\text{C}$ )	7,0	8,3	9,2	9,9	10,4	10,9	11,3	11,7	12,1	12,4
	Y ( $\Delta T = 20^\circ\text{C}$ )	4,9	5,9	6,5	7,0	7,4	7,7	8,0	8,3	8,5	8,8
	Pt	101	101	101	101	101	101	101	101	101	101
LwA	23	26	28	29	30	31	31	32	32	33	
<b>80</b> (m³/h)/tobera	Q (m³/h) conjunto	80	160	240	320	400	480	560	640	720	800
	Vk	14,0	14,0	14,0	14,0	14,0	14,0	14,0	14,0	14,0	14,0
	Y ( $\Delta T = 5^\circ\text{C}$ )	11,3	13,4	14,8	15,9	16,8	17,6	18,3	18,9	19,5	20,0
	Y ( $\Delta T = 10^\circ\text{C}$ )	8,0	9,5	10,5	11,3	11,9	12,5	13,0	13,4	13,8	14,2
	Y ( $\Delta T = 20^\circ\text{C}$ )	5,6	6,7	7,4	8,0	8,4	8,8	9,2	9,5	9,8	10,0
	Pt	132	132	132	132	132	132	132	132	132	132
LwA	26	29	31	32	33	34	35	35	36	36	
<b>90</b> (m³/h)/tobera	Q (m³/h) conjunto	90	180	270	360	450	540	630	720	810	900
	Vk	15,7	15,7	15,7	15,7	15,7	15,7	15,7	15,7	15,7	15,7
	Y ( $\Delta T = 5^\circ\text{C}$ )	12,7	15,1	16,7	17,9	19,0	19,8	20,6	21,3	22,0	22,5
	Y ( $\Delta T = 10^\circ\text{C}$ )	9,0	10,7	11,8	12,7	13,4	14,0	14,6	15,1	15,5	15,9
	Y ( $\Delta T = 20^\circ\text{C}$ )	6,3	7,5	8,3	9,0	9,5	9,9	10,3	10,7	11,0	11,3
	Pt	167	167	167	167	167	167	167	167	167	167
LwA	30	33	34	36	37	37	38	39	39	40	
<b>100</b> (m³/h)/tobera	Q (m³/h) conjunto	100	200	300	400	500	600	700	800	900	1000
	Vk	17,5	17,5	17,5	17,5	17,5	17,5	17,5	17,5	17,5	17,5
	Y ( $\Delta T = 5^\circ\text{C}$ )	14,1	16,7	18,5	19,9	21,1	22,0	22,9	23,7	24,4	25,0
	Y ( $\Delta T = 10^\circ\text{C}$ )	8,0	11,4	13,9	16,1	18,0	19,7	21,2	22,7	24,1	25,4
	Y ( $\Delta T = 20^\circ\text{C}$ )	7,0	8,4	9,3	10,0	10,5	11,0	11,5	11,8	12,2	12,5
	Pt	206	206	206	206	206	206	206	206	206	206
LwA	32	35	37	38	39	40	41	41	42	42	
<b>110</b> (m³/h)/tobera	Q (m³/h) conjunto	110	220	330	440	550	660	770	880	990	1100
	Vk	19,2	19,2	19,2	19,2	19,2	19,2	19,2	19,2	19,2	19,2
	Y ( $\Delta T = 5^\circ\text{C}$ )	15,5	18,4	20,4	21,9	23,2	24,2	25,2	26,1	26,8	27,6
	Y ( $\Delta T = 10^\circ\text{C}$ )	11,0	13,0	14,4	15,5	16,4	17,1	17,8	18,4	19,0	19,5
	Y ( $\Delta T = 20^\circ\text{C}$ )	7,7	9,2	10,2	11,0	11,6	12,1	12,6	13,0	13,4	13,8
	Pt	249	249	249	249	249	249	249	249	249	249
LwA	35	38	40	41	42	43	43	44	44	45	
<b>150</b> (m³/h)/tobera	Q (m³/h) conjunto	150	300	450	600	750	900	1050	1200	1350	1500
	Vk	26,2	26,2	26,2	26,2	26,2	26,2	26,2	26,2	26,2	26,2
	Y ( $\Delta T = 5^\circ\text{C}$ )	21,1	25,1	27,8	29,9	31,6	33,1	34,4	35,5	36,6	37,6
	Y ( $\Delta T = 10^\circ\text{C}$ )	14,9	17,8	19,7	21,1	22,3	23,4	24,3	25,1	25,9	26,6
	Y ( $\Delta T = 20^\circ\text{C}$ )	10,6	12,6	13,9	14,9	15,8	16,5	17,2	17,8	18,3	18,8
	Pt	463	463	463	463	463	463	463	463	463	463
LwA	43	46	48	49	50	51	52	52	53	53	

# SERIE T

TO - TF

FORMATO DE PEDIDO

## DESCRIPCIÓN

Conjunto de 10 multitoberas de alta inducción orientables manualmente adaptables a conducto en una fila, tipo TO-C 1x10. Acabado blanco.

### Formato de pedido:

TO

C

Filas x Nº toberas

BL

### Serie Toberas:

TO

### Montaje:

**(C)** Conducto**(R)** Rejilla

### Filas x Nº Toberas:

1 a 3 1 a 10

### Dimensiones:

(Filas x Nº toberas)

### Acabado AA:

Para terminación en **R**. Acabados Gris y BlancoPara terminación en **C**. Acabados Gris y Blanco (Perfil-remates en gris)

## DESCRIPCIÓN

Conjunto de 10 multitoberas de alta inducción fijas adaptables a conducto en una fila, tipo TF-C 1x10. Acabado blanco.

### Formato de pedido:

TF

C

Filas x Nº toberas

BL

### Serie Toberas:

TF

### Montaje:

**(C)** Conducto**(R)** Rejilla

### Filas x Nº Toberas:

1 a 3 1 a 10

### Dimensiones:

(Filas x Nº toberas)

### Acabado AA:

Para terminación en **R**. Acabado BlancoPara terminación en **C**. Acabado Blanco (Perfil-remates en gris)

